

## INSTALLATION INSTRUCTIONS

ba76107de02 03/2015

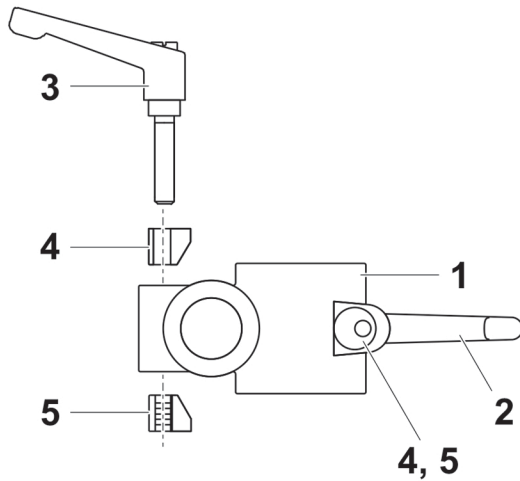

# MS/KK 170

DOUBLE JUNCTION CLAMP



a xylem brand

## Parts list

MS/KK 170

### Parts list

Pos.	Designation	Quantity
1	Body of the double junction clamp	1
2	Clamping lever M10 x 50	1
3	Clamping lever M10 x 40	1
4	Wedge without thread	2
5	Wedge with thread	2

#### Note on funktion:

Open the clamping lever only up to the point where the outrigger can be moved. If the clamping lever is unscrewed completely the wedges can get lost!

### Technical data

#### Materials

Pos.	Material
1	Cast aluminum
2, 3	Plastic-coated zinc die cast
4, 5	Stainless steel 1.4301 (V2A)